

## Stretcher Mode of KSR

Akira NODA, Makoto INOUE, Yoshihisa IWASHITA, Hiromu TONGUU,  
 Hirokazu FUJITA, Toshiyuki SHIRAI and Takashi SUGIMURA  
 Institute for Chemical Research, Kyoto University  
 Gokanoshō, Uji-city, Kyoto, 611 JAPAN

### Abstract

KSR is an electron storage ring with maximum energy and circumference of 300 MeV and 25.683 m, respectively. A pulse stretcher mode of KSR for 100 MeV electron beam from the injector linac is being prepared. By combination of three turn injection and third order resonance extraction with the repetition rate of 10 Hz, the duty factor is expected to be raised from  $2 \times 10^{-5}$  to more than 0.9. Average intensity of the electron will be increased up to  $1.5 \times 10^{12}$  pps with the reduced peak intensity of  $1.7 \times 10^{12}$  pps, while corresponding values for the direct output beam from the linac are  $1.2 \times 10^9$  pps and  $6 \times 10^{15}$  pps, respectively.

### 1 Introduction

KSR was originally designed as an electron storage ring for synchrotron light source. When operated with the maximum energy of 300 MeV, critical wavelength of the light from the dipole section is 17 nm, where the radius of curvature is 835 mm [1]. It needs, however, more time and budget before completion of KSR as a light source. Meanwhile, the injector electron linac with s-band disc-loaded type, which is shown in Fig. 1, has been completed in October, 1995 and some experiments utilizing its output beam have been started [2]. Its pulse width and repetition rate, however, are

limited below 1  $\mu$ s and 20 Hz, respectively, which results in a small duty factor of  $2 \times 10^{-5}$ . This imposes severe limitation for experiments, for example, at the experiment of Parametric X-radiation from crystal, the electron peak current and width are forced to be less than 1 mA and 10 ns, respectively in order to avoid the pileup of signals from the detector. In this condition, only single event is detected in a pulse, which needs longer time to accumulate enough events.

In order to improve this situation, a stretcher mode of KSR has been proposed to increase the duty factor of the electron beam [3]. Combination of 3-turn injection and slow beam extraction with third order resonance with the repetition rate of 10 Hz is expected to attain duty factor more than 90%. In the present paper, outline of the stretcher mode of KSR is presented in the next section and then the present status of the hardware preparation is described.

### 2 Outline of the Stretcher Mode

The time structure of the electron beam provided by the injector linac and stretcher mode of KSR are shown in Fig. 2(a) and (c), respectively, while the stored beam intensity in KSR is shown in Fig. 2(b). At the condition utilized for PXR experiment above mentioned with pulse peak and width of 1 mA and 10 ns, respectively, the average and peak intensities are  $1.2 \times 10^9$  and  $6 \times 10^{15}$  pps respectively. In the stretcher mode, beam is injected in 0.3  $\mu$ s by 3-turn injection and then after the condition for third resonance extraction is fulfilled, the beam is extracted slowly.

In Fig. 3, the phase space plot of the injection beam at the exit of the inflector is given. Three-turn injected beam rotates in a phase space ellipse with the area of  $\sim 60 \pi \text{ mm}^2 \text{ mrad}$ . The relative position of the septum is shifted with turn by pulse excitation of the pertubator. We are assuming the momentum spread of  $\pm 2\%$  for the

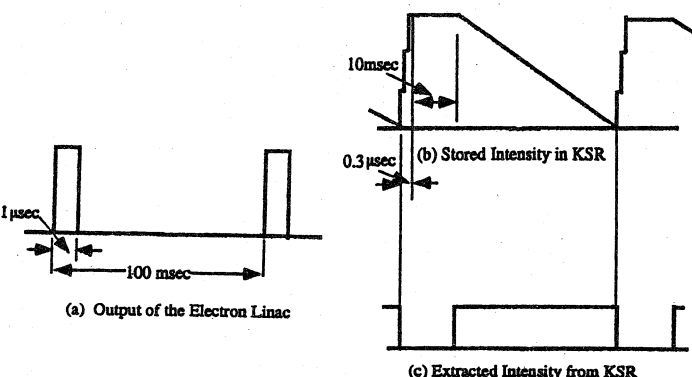

Fig. 2 Time structure of the electron linac (a), stored beam in KSR (b) and extracted beam from KSR (c).

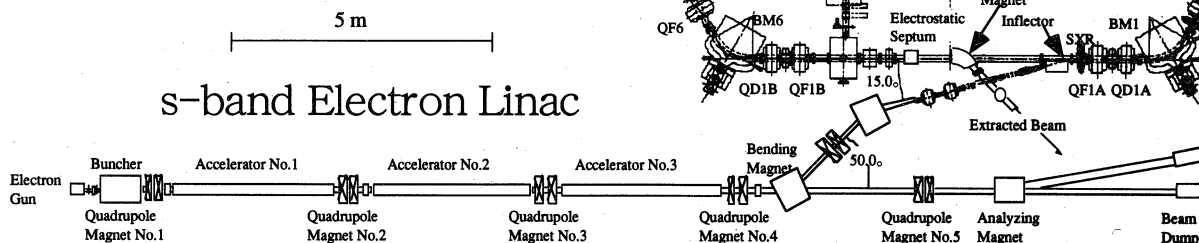

Fig. 1 Layout of KSR and its injector linac.

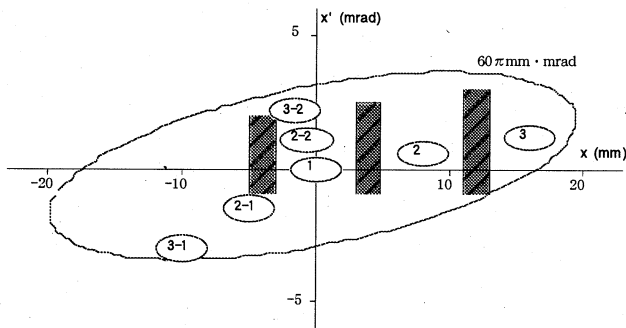

Fig. 3 Phase space plot of the injected beam at the exit of the inflector.

circulating beam in the ring. Because the long straight sections are doubly achromatic, all electrons with momentum spread have the same closed orbits in the long straight section where the inflector exists.

The electron beam injected into the stable transverse phase space ellipse is enlarged in its betatron oscillation amplitude by applying transverse RF electric field which resonates with the betatron oscillation (RF Knock-out). When the beam reaches at the separatrix, which is the boundary between the stable and unstable regions of the betatron oscillation, it comes outside rather rapidly along the outgoing separatrix as shown in Fig. 4. The tum separation of the extracted beam is calculated to be 32 mm at the first septum position 45 mm outside from the central orbit, which results in the extraction efficiency ~97% when we use septum thickness of 0.1 mm.

Electrons which jump into the gap between electrodes of the electrostatic septum (ESS) is deflected by 18 mrad and then further deflected by a septum magnet (SM) located 0.7 m down stream from the end of the ESS. In Fig. 5, the trajectories of the extracted beams are illustrated.

### 3 Apparatus for Slow Extraction

The third order resonance,  $3\nu_H=7$ , is excited by a single sextupole magnet, SXR, located just downstream of the inflector as indicated in Fig. 1. Its strength,  $B''/B\rho$ , is 0.8 T/m<sup>2</sup> and is very faint compared with those of chromaticity correction, while the magnet with the same design as the chromaticity correction is utilized.

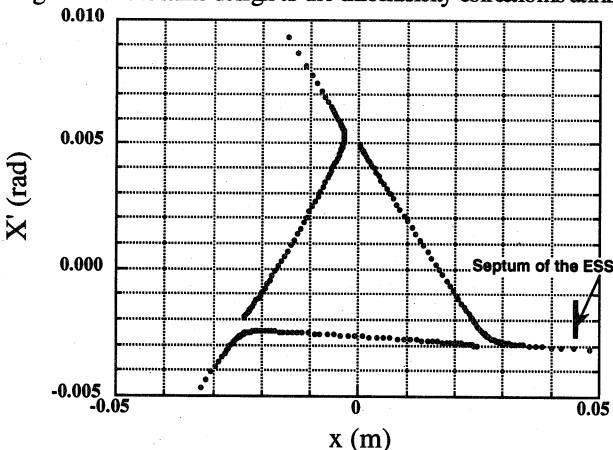

Fig. 4 Phase Space Plot at the Entrance of the ESS.

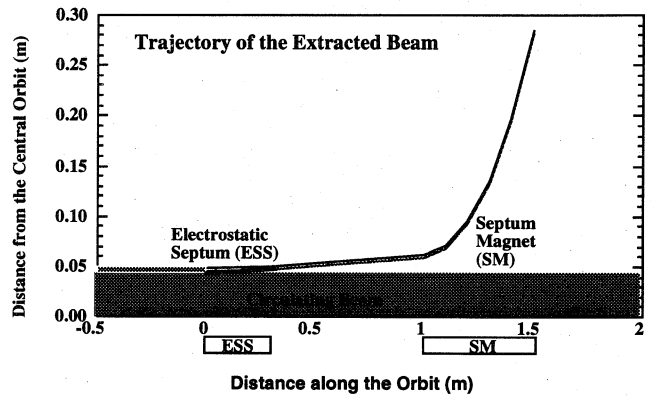

Fig. 5 Trajectories of the extracted beams.

Because the first septum is required to have very thin septum width, it should be the electrostatic one. The septum thickness assumed at the moment is 0.1 mm. In Fig. 6, the cross sectional view of the ESS is shown. The septum position is designed to be adjustable with use of 4 linear motion feedthroughs. The gap between electrodes can be changed from 5 to 35 mm. The length of the electrode is set to be 0.3 m to deflect electrons with 100 MeV as large as 18 mrad by the electric field of 70 kV/cm, which seems rather conservative value.

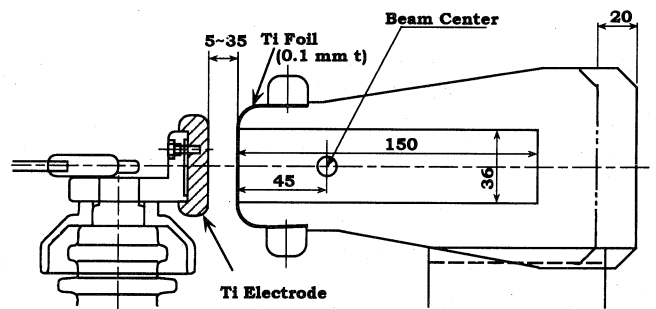

Fig. 6 Cross Section of the Electrostatic Septum (ESS).

The beam deflected by the ESS is separated from the circulating beam envelope as large as 20 mm as shown in Fig. 5. Using this space for septum coil and vacuum chamber wall, a septum magnet with the magnetic field of 0.5 T with the gap height of 20 mm is to be set 0.7 m downstream from the ESS. The septum magnet is designed to be installed outside the vacuum chamber and have curved aperture to avoid the sagitta as large as 22 mm in case of rectangular shape.

### 4 Vacuum System

In Fig. 7, the vacuum system of KSR is shown. The magnets of the KSR were precisely aligned in March 1995 with the precision of  $\pm 0.1$  mm. Vacuum chambers in these magnets were installed last summer. The arc section just down stream of the inflector has already evacuated by roughing pumps composed of rotary and turbo molecular pumps and  $5 \times 10^{-6}$  Torr has been obtained without serious leak. From the residual gas analysis, the main component is found to be water. We expect that the surface of the vacuum chamber is clean enough. Application of baking together with operation of

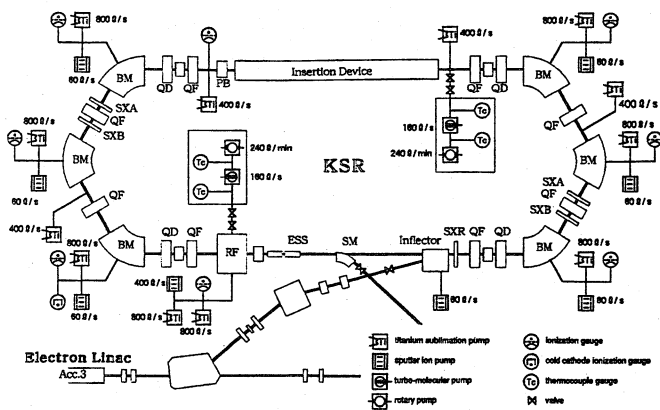

Fig. 7 Vacuum system of KSR

ion pumps and Ti getter pumps as indicated in Fig. 7 will realize the vacuum pressure as shown in Fig. 8, which is well better than the pressure needed for the stretcher mode ( $3 \times 10^{-6}$  Torr) [4]. Some improvement is required for the operation as synchrotron light source. Installation of additional ion and Ti getter pumps in the long straight sections and section around the RF cavity is being studied.

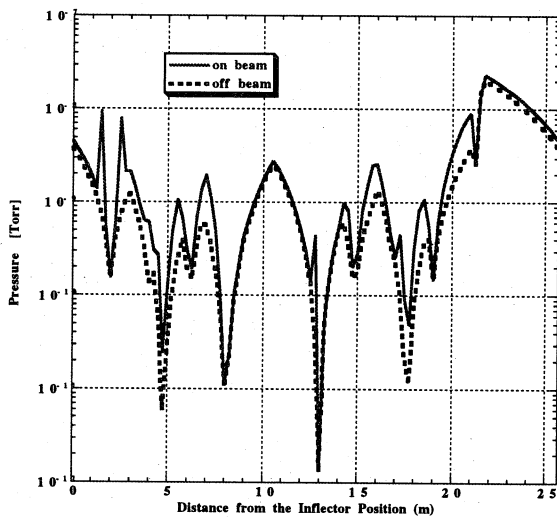

Fig. 8 Estimated vacuum pressure in KSR with (solid line) and without (dashed line) circulating electron beams.

### 5 Present Status and Time Schedule

The present status is well shown in Fig. 9, where all magnets and their vacuum chambers are already set, while the long straight sections are empty. We are now constructing the Electrostatic Septum (ESS) and Septum Magnet (SM). Vacuum chambers in the other space of the long straight sections are also to be fabricated after the final determination of the extraction system in this fall.

Preparation of the transport line from the injector linac is also underway and we will make installation of these magnets at the beginning of next year. In parallel with this, the control of various equipments such as magnet power supplies and RF power source in the shielded room from the outside control room should be



Fig. 9 Recent Overall View of KSR.

completed. These items are to be completed until the end of this fiscal year and we expect the first beam circulation in next spring.

### Acknowledgement

The authors would like to present their sincere thanks to Dr. Y. Suzuki at JAERI for his fruitful suggestion and encouragement for the present work. Their thanks are also due to cooperation of Dr. K. Mashiko. They are grateful for Mr. I. Kazama for his continuous cooperation through the whole construction stage of KSR. The construction of Stretcher Mode of KSR is supported with Grant-in-Aid for Scientific Research from Ministry of Education, Science Sports and Culture of Japan.

### References

- [1] A. Noda et al., 'Design of an Electron Storage Ring for Synchrotron Radiation', Proc. of the 4th EPAC, London, United Kingdom (1994)645.
- [2] Y. Hayakawa et al., 'Observation of Parametric X-Ray Radiation from 80 MeV Electron Beams', Beam Science and Technology, 2 (1997)8.
- [3] A. Noda et al., 'Electron Storage and Stretcher Ring KSR', Proc. of the 5th EPAC, Barcelona, Spain (1996)451.
- [4] H. Tonguu et al., 'Status of Pulse Stretcher, KSR', Proc. of the 22nd Linear Accelerator Meeting, Sendai, Japan (1997) in print (in Japanese).