

## Neutron Factory Project at KURRI

Yoichi KAWASE, Makoto INOUE\* and Future Plan Working Group  
Research Reactor Institute, Kyoto University, Kumatori, Sennan, Osaka, 590-04 JAPAN

\*Institute for Chemical Research, Kyoto University, Uji, Kyoto, 611 JAPAN

### Abstract

An intense neutron source based on a hybrid system of linear accelerators and a subcritical assembly has been proposed as a future plan of the Research Reactor Institute, Kyoto University (KURRI). The injector linac provides 300 MeV, 0.3mA protons to produce neutrons which are multiplied by a subcritical uranium assembly. This system is expected to bring new opportunities as a second generation neutron source at KURRI.

### 1. Introduction

The Kyoto University reactor(KUR) has been providing low energy steady neutrons for various research fields such as reactor physics, nuclear physics, nuclear chemistry, biology and medicine. According to the recent progress in each field, strong requirements for high energy and pulsed neutrons have increased and a "new neutron source" has been discussed in the working group of the future plan committee of KURRI to meet the requirements. A particle accelerator and neutron multiplier combination is proposed as one of possible candidates.

The particle accelerator part of the Neutron Factory project is given in this report and the target part has been elsewhere [1].

### 2. Particle accelerators

The primary particles to produce neutrons efficiently are high energy proton and deuteron which can be accelerated advantageously by a linear accelerator(LINAC) at high beam intensity [2]. In order to obtain intense neutrons, the attainable energy of the primary particle should be as high as possible. However, taking into account the present situation at KURRI, it is desirable that the reactor technology is effectively applied to produce neutrons in combination with a moderate size linac.

Many requirements for various kinds of neutrons arise from research experiences at KUR. Pulsed neutrons for neutron scattering experiments are strongly required by solid state physicists. Ultra cold neutrons, on the other hand, are very important for elementary particle physics. The medical use of epithermal neutrons by the Boron Neutron Capture Therapy(BNCT) method is hopeful on the base of experiences at KUR.

We propose here the Neutron Factory, a hybrid system of particle accelerators and a subcritical assembly, which is shown in Fig. 1. Deuterons or hydrogen molecules of 100 mA beam intensity extracted from a high current ion source are accelerated to 400 keV by the first RFQ. The second RFQ makes the beam energy high up to 2 MeV by the 10% duty pulse operation. The drift-tube-line (DTL) linear accelerator is operated at 1% duty to get the beam energy of 20 MeV. For the higher energy than 20 MeV, the proton acceleration is economical. Therefore the 20 MeV  $H_2^+$  beam which can be accelerated by the deuteron linac is stripped before the second stage DTL. Finally, we obtain a proton beam of 300 MeV and 0.3 mA by a Disk and Washer (DAW) linear accelerator.

In each stage of the particle energy, every variety of neutrons become available as follows.

#### 1) 14 MeV neutrons

Among the neutron producing reactions, the (D,T) reaction has the largest cross section. It reaches 5 barn at 105 keV deuteron bombarding energy. By using 400 keV deuterons from the first RFQ, intense 14 MeV neutrons can be generated and used for the study of fusion reactor materials. Difficult problems arising from a large amount of tritium targets should be solved.

#### 2) Epithermal neutrons

The second RFQ generates about 3 MeV neutrons by the deuteron bombardment on the Be target.

NEUTRON FACTORY PROJECT at KURRI

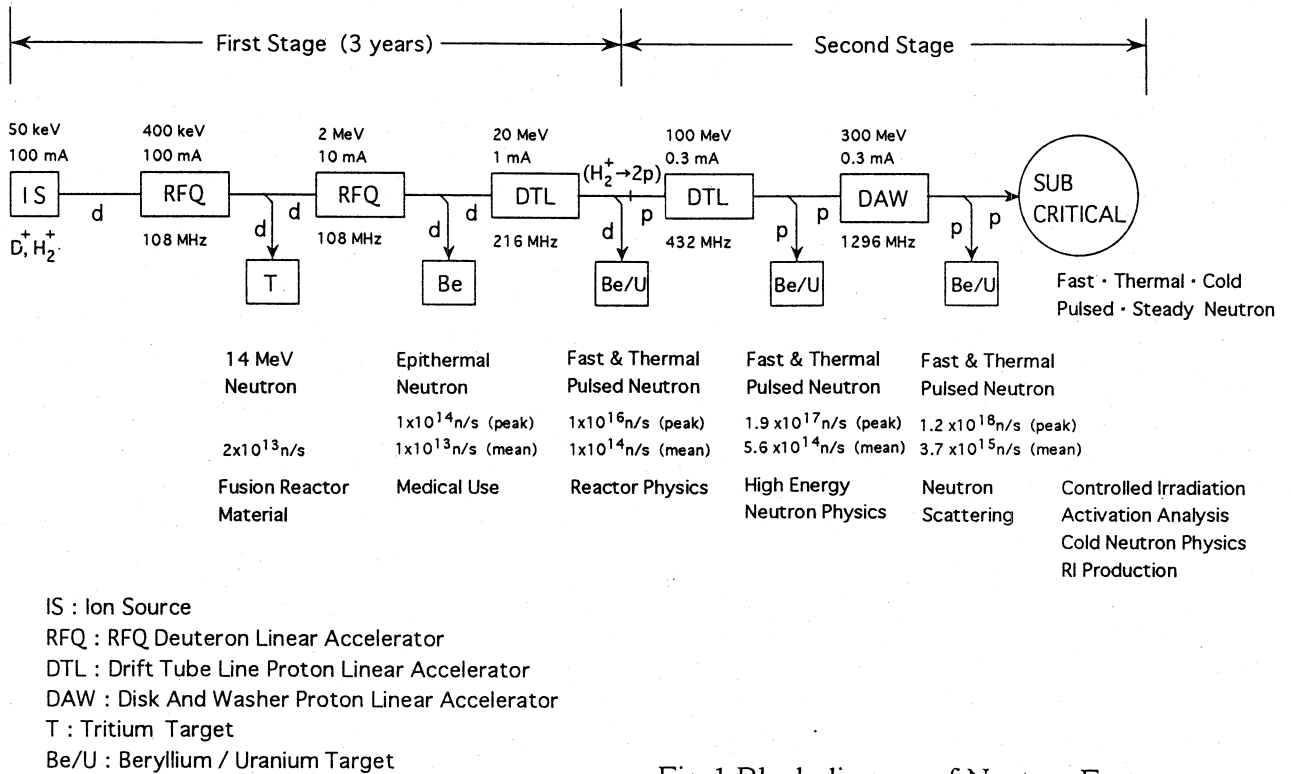

Fig. 1 Block diagram of Neutron Factory

They can be moderated down to epithermal neutrons which are efficiently used for the BNCT. The fundamental study on BNCT presently done with thermal neutrons at KUR can be upgraded by utilizing high quality epithermal neutrons.

3) High energy pulsed neutrons

The 20 MeV deuterons obtained by the DTL LINAC can produce about 10 MeV pulsed neutrons by the  ${}^9\text{Be}(d,n)$  stripping reaction. The DTL is operated at 1% duty and high energy neutron experiments such as the T.O.F. spectroscopy in reactor physics become possible.

4) Intense pulsed neutrons

The final energy and beam intensity of the primary particles are planned to be 300 MeV and 0.3 mA, respectively, which allow the mass production of high energy neutrons by a spallation reaction. We can expect the neutron intensity of  $1.2 \times 10^{18}$  n/s at peak and  $3.7 \times 10^{15}$  n/s in mean,

which enables neutron scattering experiments for structure analysis of condensed matters.

5) Neutrons for irradiations

A final goal of the Neutron Factory project is to inject spallation neutrons into a subcritical assembly to multiply them safely and efficiently. Details of the target system should be studied[1]. Intense neutrons can make great evolution in research fields such as precisely controlled irradiation of materials and the cold neutron physics which require much more than presently available at KUR.

In Fig. 2, the layout of the Neutron Factory is illustrated including KUR and KUACA. The low energy deuteron beam enters KUACA to be used as a 14 MeV neutron generator and test experiments for the subcritical neutron source will be started here. A beam course for the medical use is installed at the 2 MeV station. The injection of 20

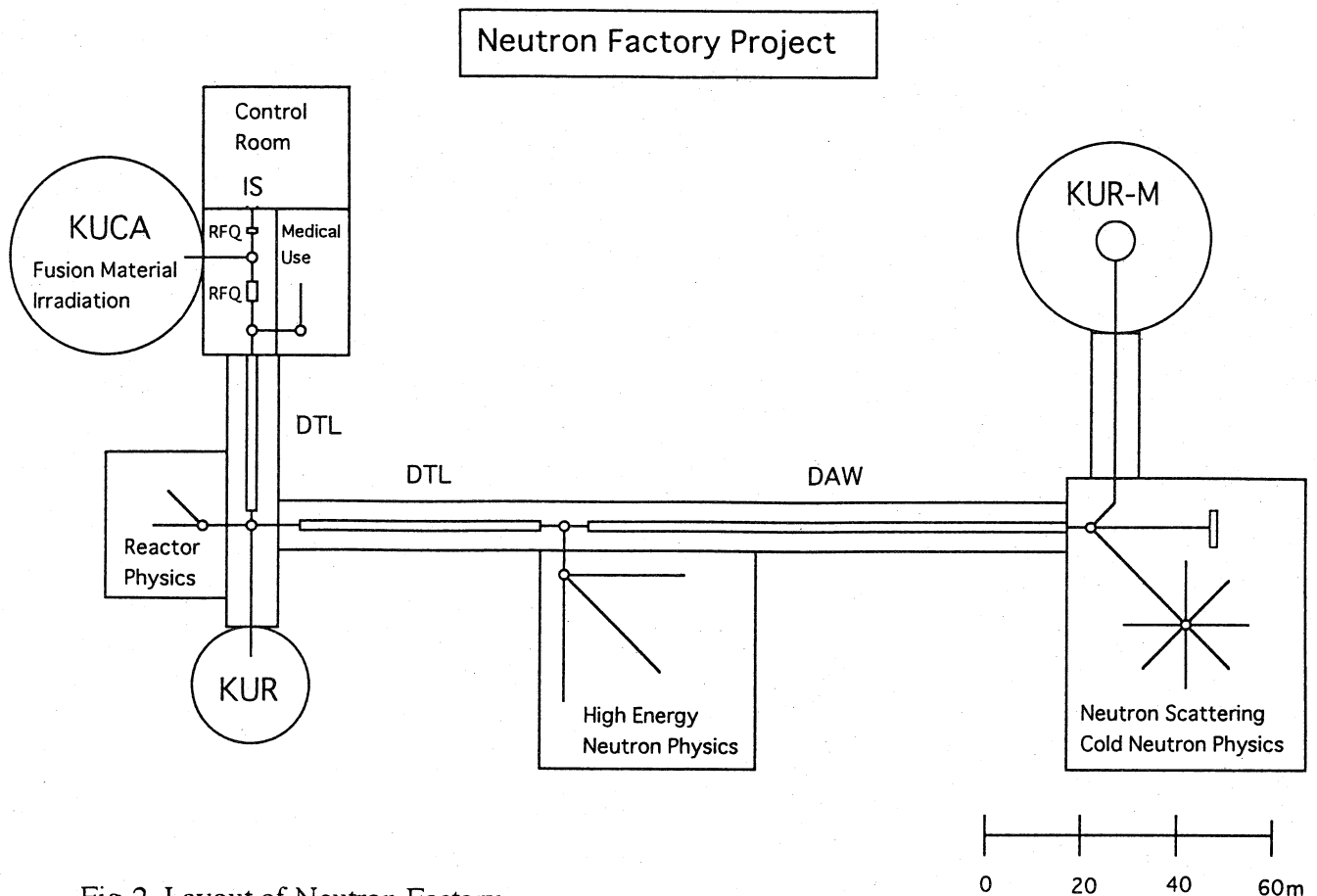

Fig. 2 Layout of Neutron Factory

MeV deuterons to KUR involves many problems to be solved. It is most desirable to construct a new target system at the 300 MeV terminal.

### 3. Summary

In order to offer opportunities to utilize high energy pulsed neutrons as well as low energy steady neutrons, the KURRI has taken the first step toward the realization of a multipurpose neutron source involving particle accelerators. The nuclear hybrid system itself is very interesting and worthwhile because it involves many technical subjects in both accelerator technology and nuclear engineering. We hope that this proposal will be discussed and polished up by those who are interested in neutrons, accelerators and nuclear systems.

### References

- [1] S. Shiroya, Reports on Kyoto-University Accelerator Projects, p. 163(1997)(In Japanese)
- [2] "Neutron Sources for Basic Physics and Applications". An OECD/NEA Report, ed. S. Cierjacks, Pergamon Press, 1983.