

HIGH POWER TEST OF A 500 MHz RF CAVITY OF A CW MICROTRON FOR INDUSTRIAL APPLICATIONS

Yo Makita, Tetsuya Nakanishi, Yuehu Pu, Hirofumi Tanaka, Akihiko Maruyama, Tae Hyun Kim, Chihiro Tsukishima, Shunji Yamamoto and Shiro Nakamura,

Mitsubishi Electric Corp., Advanced Technology R & D Center,
8-1-1 Tsukaguchi-honmachi, Amagasaki, Hyogo 661-8661, Japan

Abstract

A 500 MHz RF cavity of the CW microtron was fabricated and high power test has been carried out. The cavity has 2-cells with nose cones and coupling slots. Inductive Output Tubes (IOTs) are used as RF power sources. PC based control system with NI-PXI system was adopted for tuner feedback, remote control and measurements. The input power of 40 kW was successfully obtained.

1 INTRODUCTION

High power electron beams are necessary for industrial applications: X-rays irradiation and electron irradiation. Accelerators operated with a continuous wave (CW) mode are of considerable practical interest for industrial applications from a point of view of supplying a high intensity beam [1-3]. We have been developing a CW microtron with a 500 MHz RF cavity [4, 5]. Figure 1 shows a schematic drawing of a 5MeV microtron. Basic parameters are shown in Table 1.

For a conventional microtron, an S-band cavity is widely used. Although, it is not suitable to use this type of cavity due to a heat problem in case of applying for high intensity machines. Due to the problem above, a 500 MHz cavity, which is frequently used to an electron storage ring, was adopted. Currently, we have already done the design, the fabrication and power tests of the RF cavity. This paper describes the result of the high power test.

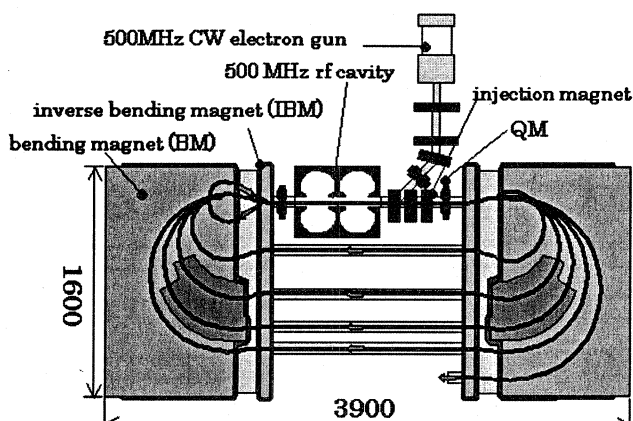

Figure 1. Schematic drawing of the 5 MeV CW microtron

Table 1: Parameters of the CW microtron

Energy	5 MeV
Average beam current	10 mA
Average beam power	50 kW
Injection energy	80keV
The number of turns	6
RF frequency	500 MHz
Wall loss of the RF cavity	40 kW

2 DESCRIPTION OF RF CAVITY AND RF SYSTEM

Figure 2 shows a cross sectional view of the RF cavity. The cavity has 2-cells with nose cones and coupling slots. The selected resonant frequency of 500 MHz is mainly based on the consideration of input RF power and the total size of the accelerator.

The cavity is designed to operate in the π -mode. Nose cones and rounded shape of the cavity design were applied to obtain the higher shunt impedance. An optimum gap length was calculated since the injection energy is 80 keV ($\beta=0.5$), and the velocity of an electron beam changes with every turn. We have done the RF analysis by using SUPERFISH and MAFIA codes. A thermal and structural analysis was done by using ANSYS code. The frequency shift due to the thermal deformation, temperature rise and the stress distribution was estimated [6, 7].

The material of the cavity is class 1 oxygen free copper (OFHC) so that high electrical and thermal conductivity and low out-gassing rate can be obtained. The design parameters of the cavity are shown in Table 2.

Table 2: Parameters of the RF cavity

Number of cells	2
Cell length	299 mm
Outer diameter	510 mm
Bore diameter	65 mm
Gap length	170 mm
Gap volt. /2cell	1 MV
Unloaded Q value	37400

At the operation of 5MeV-50kW, an electron beam consumes 50 kW and a wall loss of the RF cavity consumes approximately 40kW by the RF analysis. Therefore, an RF power supply with 500MHz-100kW is required for the RF system. We used two 500MHz-50kW

Inductive Output Tubes (IOT, CPI Model K2H50), which are commonly used for broadcasting systems, as a 100 kW power source by combining outputs from the IOTs by a magic tee. A coaxial line instead of a waveguide was adopted to make the system compact.

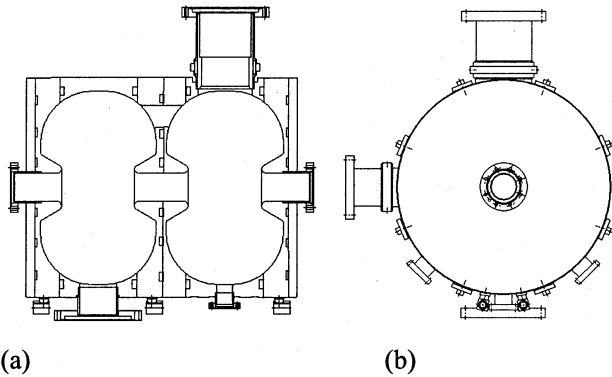

Figure 2. Cross sectional view of the RF cavity. (a) side-cut view, (b) axial-cut view

2 HIGH POWER TEST

2.1 Set-up

Since the high power conditioning was done without beam so that the coupling coefficient of the input coupler was adjusted to 1.0. A 500 l/sec turbo molecular pump was attached to the vacuum port and two ionization gauges were placed at vacuum gauge ports. The flow of cooling water of each cell was set to 50 l/min, and 30 l/min for other components such as tuning plungers, the coupler and the coaxial line. A ceramic window at the coupler was cooled by forced air flow. The temperature distribution of the outside wall of the cavity and the water temperature were monitored by thermo couples. Figure 3 shows the set-up of the high power conditioning.

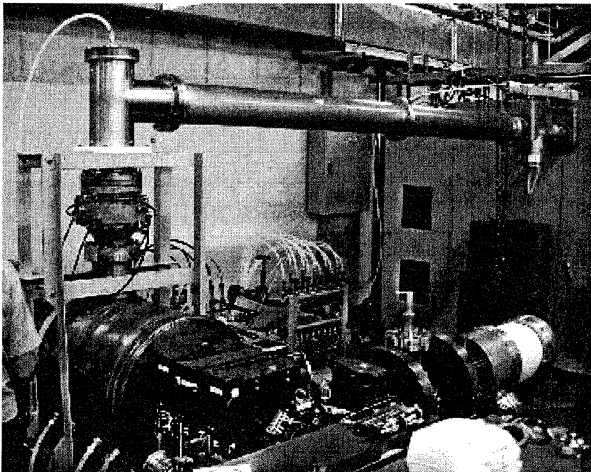

Figure 3. The RF cavity placed in the microtron and a coaxial line for RF power feed.

Figure 4 shows the feedback system. The operations were controlled by a PC based control system using National Instrument (NI) PXI system. For remote control of the RF power source, a digital I/O module, NI-PXI6533, was used. Monitoring of forward and reflected power, tuner position, temperature and the cavity pressure, and feedback control of the tuner were done by ADC and TTL pulse train by using NI-PXI6040E module. A simple program to control the tuner position was made by LabVIEW, which keeps the cavity on resonance.

As for interlocks for the system, signals of reflected power, vacuum pressure and arc detectors located at the ceramic window of the input coupler were hard-wired into the input RF signal of the power supply. The vacuum interlock was set to turn off the RF power supply at 5×10^{-5} Torr to avoid high power operation with bad vacuum which may cause severe problem to the ceramic window and so on.

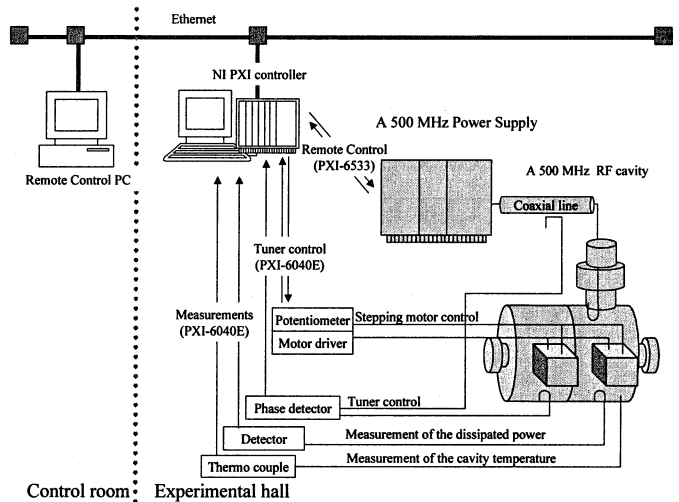

Figure 4. The schematic view of the control system.

2.2 High Power Conditioning

Figure 5 shows the whole progress of the conditioning. At first, the RF power was fed at a power level of several hundreds of watts. Then, the input power was gradually increased in order to keep the cavity pressure below 5×10^{-5} Torr. The conditioning progressed smoothly without any serious problems. After conditioning for 62 hours an input power of 40 kW and reflected power 2.2 kW were attained. There is a lower power conditioning done around the running time of 35 hours. This is due to leakage of cooling water around the coupler occurred. We have carefully ensured that no severe trouble was found in the coupler.

The vacuum pressure without input RF power, before starting the test, was 8.6×10^{-7} Torr. The vacuum pressure of the cavity after the completion of the conditioning, without RF power, was 6.2×10^{-8} Torr as shown in Fig. 5.

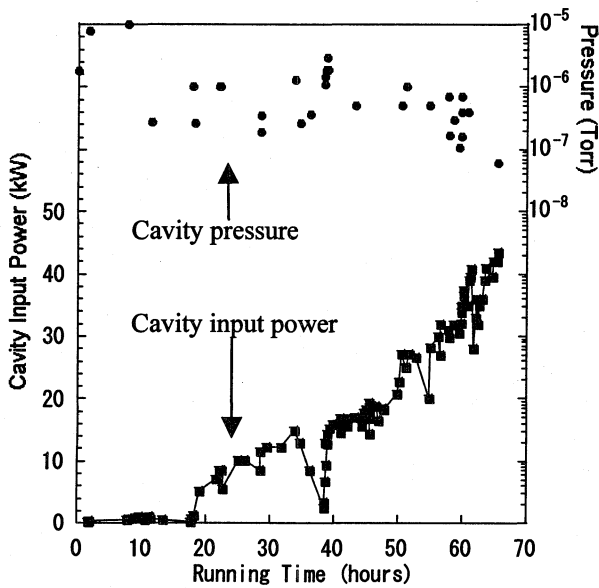

Figure 5. The progress of the high power conditioning. The cavity input power and the cavity pressure are plotted as a function of the conditioning time.

Table 3 shows the measured and calculated temperature rise in each point during 40 kW operation. Thermal analysis was done by ANSYS code with a half cell model. A symmetric boundary condition was applied along the line marked with "S" in Fig. 6. A heat load distribution on the inner surface of the cavity was calculated by SUPERFISH. Three dimensional structures such as a coupler port and coupling slots were neglected. Two groups of water channels, C4 and C1-C2-C3, were taken into account since we designed that C1, C2 and C3 are serially connected and C4 flows in parallel. Temperature in each channel shows the average water temperature. Detailed description is given in Ref. [7].

The calculation result and measured positions are given Fig. 6. The measured temperature rises were in agreement within a factor of two.

Table 3: Measured and calculated temperature rise of the cavity at 40 kW operation.

Position	Measurement (°C)	Calculation (°C)
a	10.9	12.2
b	4.5	7.9
c	11.1	14.3
d	9.7	-

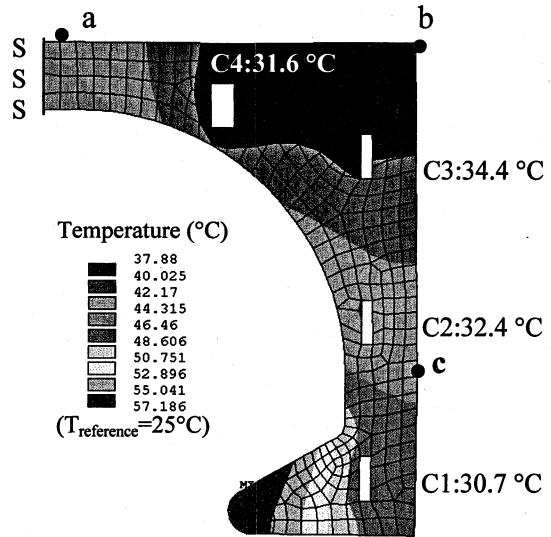

Fig. 6 Temperature distribution of the cavity for total power dissipation of 40 kW calculated with ANSYS code. Measured position are given in a, b and c.

3 CONCLUSION

We have done the high power test of the 500 MHz RF cavity. The input power of up to 40 kW demonstrated the capability of the cavity. PC based control systems such as a tuner feedback of the cavity, a remote control of a power supply and other monitoring systems are established and operated without any problem. The measured temperatures rises were in agreement within a factor of two. The acceleration beam test will be performed by the end of this year.

REFERENCES

- [1] J.M.Bassaler et al., Nucl. Instr. Meth. in Phys. Res. B 68 (1992), p.92.
- [2] A. J. Stirling, Proc. 5th European Particle Accelerator Conf., Barcelona (1996).
- [3] H. Kwon et al., Proc. Particle Accelerator Conf., New York (1999) p. 2558.
- [4] H. Tanaka et al., Int. J. Appl. Electromagnetics Mech. 14 (2001/2002) p.177.
- [5] T. Nakanishi et al., in these proceedings.
- [6] Y. Pu et al., Nucl. Instr. Meth. in Phys. Res., to be published.
- [7] Y. Makita et al., Proc of the 13th Symp. on Acc. Sci. and Tech., Osaka (2001) p. 244.