

INSERTION DEVICE CONTROL AT NEWSUBARU

Y. Shoji[#], and S. Miyamoto, LASTI, University of Hyogo, 671-2222, Japan

Abstract

Correction of insertion device (ID) induced tune shifts and orbit distortions are performed by means of feed forward schemes. The remaining orbit fluctuations will be suppressed by a slow COD feed back system. As a result, a stability of a few tens micron-level at the BPMs will be achieved while the ID gaps are varied.

INTRODUCTION

The 1.5 GeV electron storage ring NewSUBARU [1] has been constructed in the SPring-8 site in 1998. It shares the 1.0 GeV linac of SPring-8 [2] with the Synchrotron as an injector. The ring is a racetrack type with the circumference of 119 m and has two 14 m long (LSS) and four 4 m long (SSS) straight sections. In the LSSs the 10.7 m long undulator (LU) [3] and an optical klystron for FEL (OK) have been installed. In one of the SSSs the 2.4 m long wiggler (we call it as short undulator; SU) has been installed. The main parameters of the ring and the insertion devices are summarized in Table I and Table II, respectively.

Table I: Main parameters of the NewSUBARU

Electron Energy	0.5 - 1.5 GeV
Injection Energy	1.0 GeV
Circumference	118.731 m
Type of Bending cell	modified DBA
Number of Bending Cell	6
RF Frequency	499.956 MHz
Harmonic Number	198
Maximum Stored Current	500 mA /ring
Betatron Tune ν_x/ν_y	6.30 / 2.23
Chromaticity ξ_x/ξ_y	3.2 / 5.8
Natural Emittance at 1 GeV	38 nm
Natural Energy Spread at 1 GeV	0.047%

Table II: Main parameters of the Insertion Devices

Insertion Device	LU	OK	SU
type	planner	planner	planner
magnet	NdFeB	EM	NdFeB
number of periods	198	65/33	30
length of periods	54	160/320	76
K-value	0.3-2.5	0.3-4.4 0.3-11	0.3-5.3
gap	119-26	---	126-26

Now we are installing new control system of IDs, which enables a gap control by users without a change to the stored beam visible from the other beam lines. With this new system beam line users can develop more complicated system, such as XAFS, without any interference with the machine control. The system

contains the feed-forward correction system of the tune shifts and the orbit distortions [4]. In addition, we will install the slow cod feedback system [5].

CORRECTION MAGNETS

Quadrupole Correction

According to the tune diagram survey near the present working point, $\nu_x=6.30$, $\nu_y=2.22$, the acceptable vertical tune shift was ± 0.03 . On the other hand, the expected maximum vertical tune shifts by LU or SU is $\Delta\nu_y=+0.06$ [4]. Therefore, we cannot skip the correction of tune shifts by IDs. Basically the correction was performed by the correction windings on the lattice quadrupoles. Table III is the list of the quadrupole families set at the dispersion free sections of NewSUBARU, two families at SSS and three at LSS.

The SU is set at one of the SSSs as shown in Figure 1. The tune shift by SU is cancelled out using correction windings on two pairs of quadrupoles, which belong to Q1 and Q2 families. The calculated tune shifts by these quadrupoles are listed in Table IV. Figure 2 shows the modulation of the beta functions, β_x and β_y , by SU with and without the tune shift correction. When the gap of SU is closed, the modulation of β_ψ is roughly $\Delta\beta_\psi/\beta_\psi=\pm 40\%$. With the quadrupole correction the modulation of β_ψ is reduced to $\Delta\beta_\psi/\beta_\psi=\pm 4\%$ except at the SSS of SU. The modulation of β_x produced by the tune correction is only $\Delta\beta_x/\beta_x=\pm 1\%$.

Table III: Quadrupole families at the straight sections

straight section magnet family	SSS		LSS		
	Q1	Q2	QA	QB	QC
Effective length (m)	0.23	0.23	0.33	0.43	0.33
β_x (m)	9.5	3.4	32	13	5.5
β_y (m)	14	25	19	33	29
bore radius (mm)	70	70	70	70	70
number of magnets	8	8	8	8	8

Table IV: Setting for the tune shift correction of SU.

magnet family	Q1	Q2	total
number of magnets	2	2	
correction winding (turn/pole)	5	15	
correction current	-9.5	8.9	
Tune shift $\Delta\nu_x$	-0.0102	+0.0102	0
$\Delta\nu_y$	0.0150	-0.0753	-0.0603

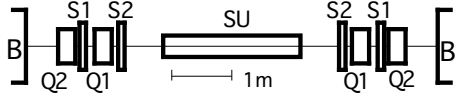

Figure 1: Layout of magnets near SU.

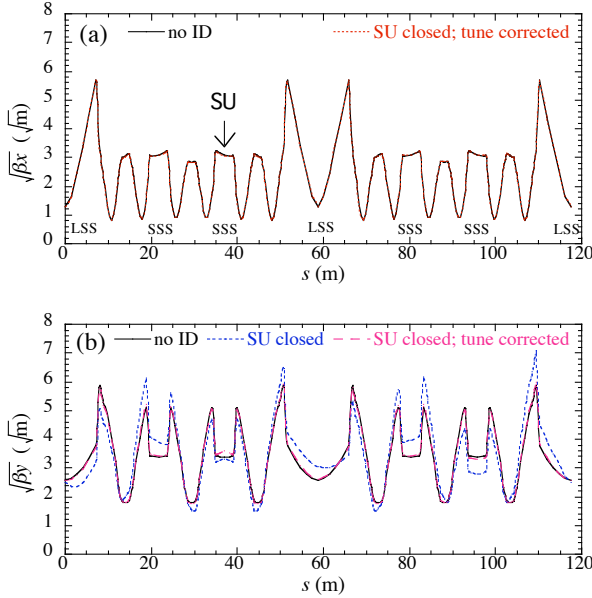

Figure 2: The effect of SU on the (a):horizontal and (b):vertical beta functions around the ring. The solid lines show the functions with the gap of SU opened. The dotted line shows the function with the gap of SU closed and no tune shift correction. The broken lines show the beta functions with the gap of SU closed and the tune shift is corrected.

For the correction of the tune shift by LU we considered the following 4 quadrupole configurations.

- (I) Use two pairs of correction windings on the nearest pairs of quadrupoles to LU, QA and QB.
- (II) Use Q1 & Q2 families. This is the present way of correcting the tune shift.
- (III) Use QB on the opposite side of LU as an additional correction knob to the configuration (I).
- (IV) Make a correction quadrupole winding at the centre of LU and use it with the configuration (I).

When the gap of LU is closed, the modulation of β_y is roughly $\Delta\beta_y/\beta_y = \pm 20\%$. This modulation is smaller than that of SU for the same tune shift, because the phase advance along LU is larger. The tune shift correction by the configuration (I) enlarged the modulation to about $\Delta\beta_y/\beta_y = \pm 40\%$ as shown in Fig. 3. This is because the betatron phase advance from the LU center to QB is as large as ± 49 degrees. The configuration (I) is not a good choice.

Figure 4 shows the modulations of the vertical beta function $\Delta\beta_y/\beta_y$ and the phase nodulation

$$\Delta\phi_y = \int \left[\frac{1}{\beta_y + \Delta\beta_y} - \frac{1}{\beta_y} \right] ds.$$

The configuration (IV) is the best but it has a technical difficulty of constructing the correction quadrupole at the center of LU. The configuration (III) is the second best from the viewpoint of the small $\Delta\beta_y/\beta_y$. However it has large $\Delta\phi_y$. The configuration (II) does not have large $\Delta\beta_y/\beta_y$ neither large $\Delta\phi_y$.

Our decision is that we do not fix the configuration now and construct the system with which both (II) and (III) are possible because our ring model has considerable uncertainty [6].

Table V: Quadrupole families at LSS.

magnet family	QA	QB	QC
number of magnets	2	2	2
β_x (m)	32	13	5.4
β_y (m)	16	33	28
Difference from LU centre	s (m)	± 7.4	± 8.9
	ϕ_x (deg)	± 77	± 86
	ϕ_y (deg)	± 47	± 51

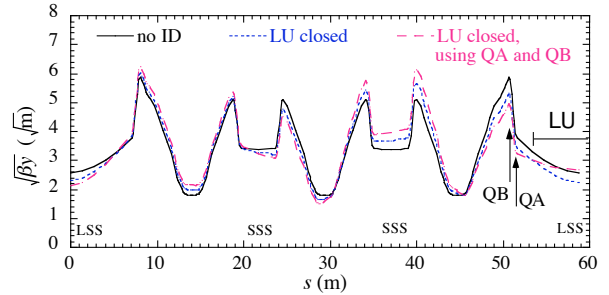

Figure 3: The effect of LU on the vertical beta functions around the ring. The solid lines show the functions with the gap of LU opened. The dotted line shows the function with the gap of LU closed and no tune shift correction. The broken lines show the beta functions with the gap of LU closed and its tune shift is corrected.

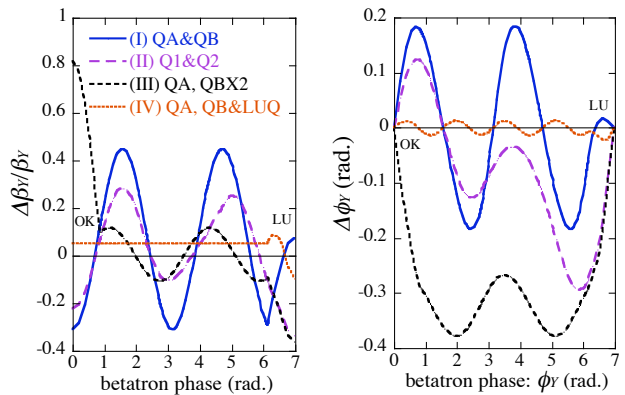

Figure 4: Modulation of the beta function (left) and the betatron phase (right) after the correction of the tune shift by LU.

Dipole Correction

The correction of the COD excursion is cancelled by air-core correction coils set on the support frame of the undulators (Figure 5). They move with the gap, therefore the correction field is not always the same for the same coil current. However that is not a serious problem.

For the each direction, horizontal and vertical, SU has two sets of coils, at the up-stream side and the down-stream side. LU has four sets for the vertical direction and two sets for the horizontal direction. The vertical direction has two extra degrees of freedom of the correction, which are used to adjust the vertical orbit in the undulator.

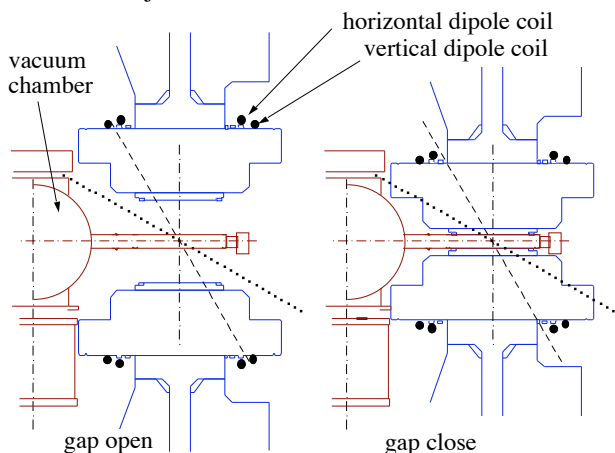

Figure 5: Cross section of the undulator frame with the vacuum chamber. The black circles are cross sections of air-core coils, which produce the dipole correction field. When the horizontal dipole coil is on the broken line, the sextupole field component is zero and when the vertical dipole coil is on the dotted line, the skew-sextupole field component is zero.

Skew Quadrupole Correction

As skew quadrupole correction is necessary for the good injection efficiency at the top-up operation. At the present we use a set of correction skew quadrupole magnet for LU. However we are going to reduce that gap-dependent skew quadrupole component by adding shim plates. We will use an air-core coil on the undulator frame only when it is necessary.

COMPUTER CONTROL SYSTEM

The control system of IDs and that of the accelerator are basically different. The former is the PLC system (MELSECNET/II, Mitsubishi Electric Co. Ltd.) and the latter is the UNIX system. Figure 6 shows a schematic view of the PLC system for ID control. A serial communication line (RS232C) is used for the communication between them. This line works to protect the accelerator control network from that of the ID users. The ID users change the ID gap from the local control graphic panel set at the beam line but they cannot change parameters of the accelerator. On the other hand operators in the accelerator control room can change ID gaps

through the accelerator control system. We have an upgrade plan of the communication between the two systems, from RS232C to FL-NET [7].

The ID control system has a parameter table for the feed-forward correction. For a given ID gaps and electron energy (1.0GeV or 1.5GeV) the table gives the list of currents of the correction elements. The time for applying one set of parameters is roughly 1 sec. This limits the speed of changing ID gaps to roughly 0.1mm/sec. With this speed the feed-forward system cancels the orbit shift within 0.01mm at $\beta=10m$, about 1/60 of the standard deviation of the beam size.

Slow COD feedback system, which is now under the development [5], will be used as an additional orbit correction.

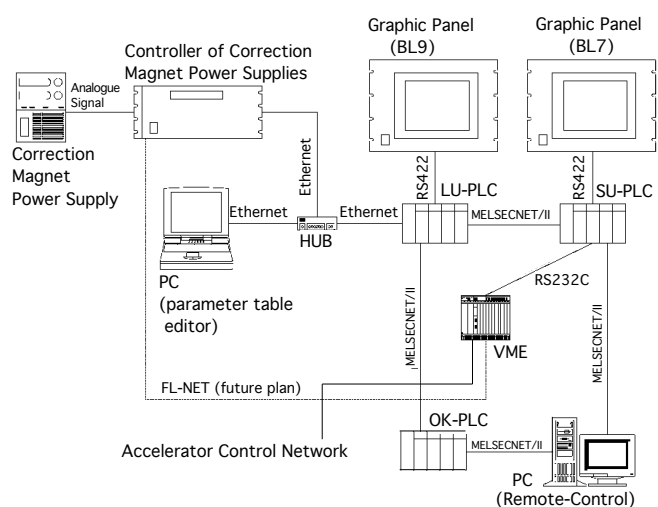

Figure 6: Control system of insertion devices and correction magnet power supplies. VME is a part of the accelerator control system.

ACKNOWLEDGEMENT

The authors thank Dr. T. Fukui of SPring-8 control group for giving us many suggestions about the computer control system. He also takes part of preparing the system on the VME-UNIX and the connection between the PLC and UNIX systems.

REFERENCES

- [1] A. Ando, *et al.*, Jour. Synch. Rad.5 (1998), 342.
- [2] H. Hanaki, *et al.*, "Improvements of Machine Reliability and Beam Quality in SPring-8 Linac for Top-Up Injection into Two Storage Rings", PAC'05.
- [3] M. Niibe, *et al.*, AIP CP705, p.576 (2004).
- [4] Y. Shoji, *et al.*, AIP CP705, p.247 (2004).
- [5] Y. Shoji and H. Fukuda, "circumference and cod control algorithm of NewSUBARU", this proceedings.
- [6] Y. Shoji, Proc. of sast'01, p.310.
- [7] T. Fukui, *et al.*, "Development of a Communication with PLC by using the FL-net as open standard PLC Link", PCaPAC'05.